

MAP OF SERRATOGA FALLS METROPOLITAN DISTRICT No. 2

TOWN OF TIMNATH, COUNTY OF LARIMER,
STATE OF COLORADO
LGID #65580

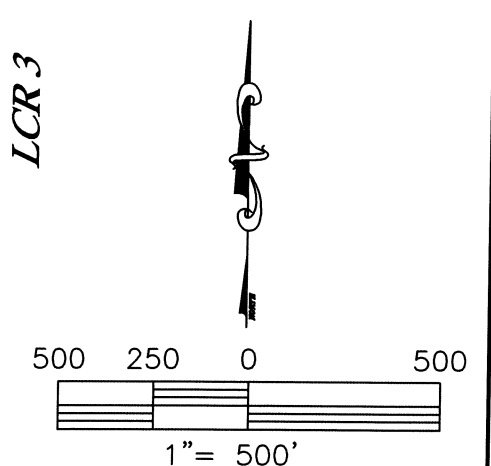

NOTE: This exhibit drawing is not intended to be a monumented land survey. It's sole purpose is as a graphic representation to aid in the visualization of the written property description which it accompanies. The written property description supersedes the exhibit drawing.

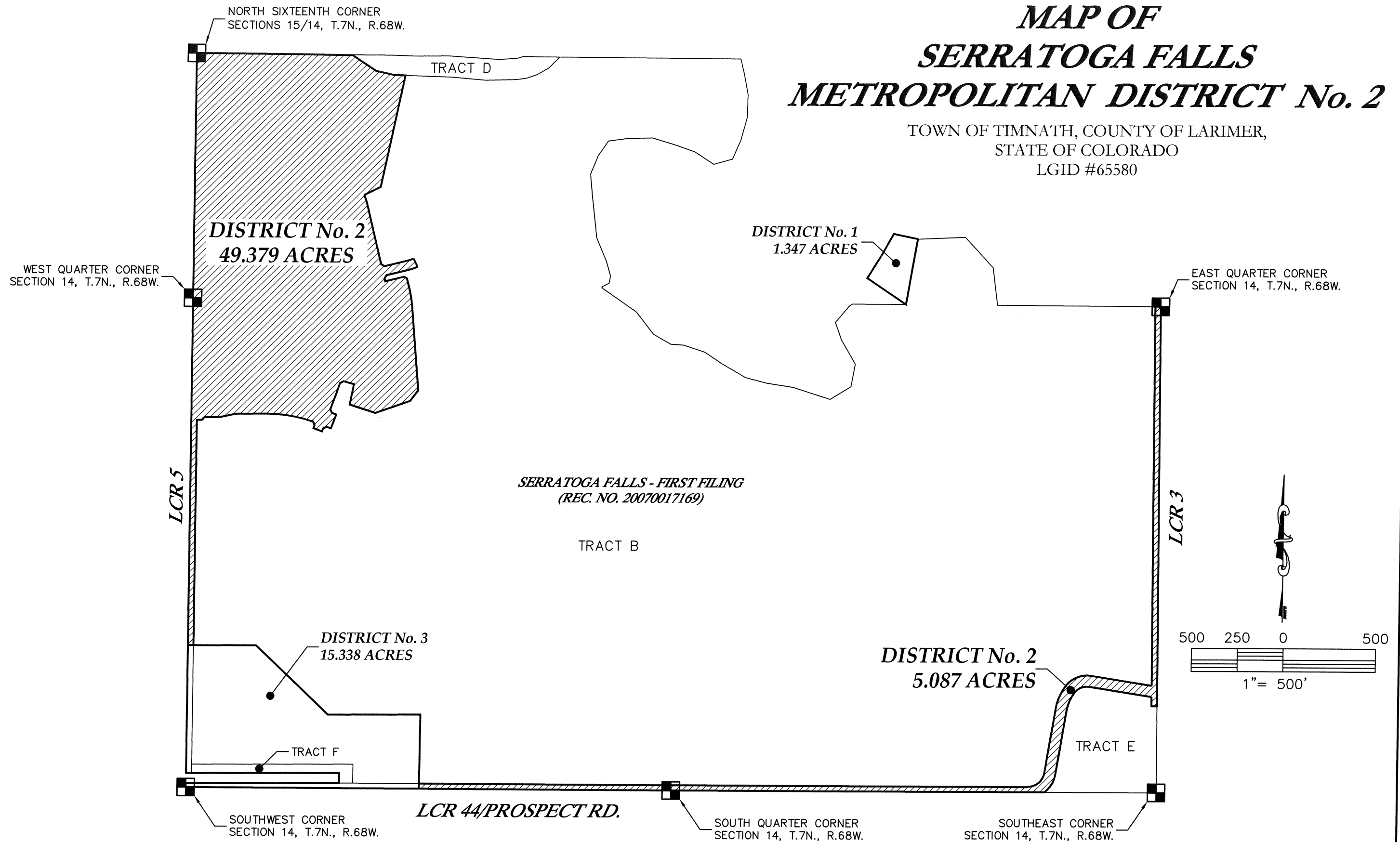

KING SURVEYORS

650 E. Garden Drive | Windsor, Colorado 80550
phone: (970) 686-5011 | fax: (970) 686-5821
www.kingsurveyors.com

PROJECT NO: 20160985
DATE: 12/29/2016
CLIENT: SETER & VANDER WALL
DWG: 20160985METRO
DRAWN: CSK **CHECKED:** MCD